



MARTEN



COLTRANE
SUPREME

II

MADE IN SWEDEN



COLTRANE
SUPREME
II

Our goal was simple. To design the best speaker in the world. With the Coltrane Supreme 2, we've arrived at where we want to be. Our ultimate design.

To create the ultimate speaker, we needed an absolute reference point. We recorded our own album, 'Supreme Sessions.' The result? With eyes closed, the playback of the recording is identical to the live performance. The live feeling of the music, played by the musicians at the point of the recording, is reproduced in every detail.

Simply, the Coltrane Supreme 2 has a sound quality so genuine that distinguishing between recorded music and reality is not possible.

High Fidelity in its essence.

In fulfilling our dream of creating the best speaker in the world, no corners have been cut. No compromises made. Every single element is the best, period.

The sides are made of 27mm thick carbon fibre laminate, layered with 45mm 5-layered wood. The carbon fibre laminate is two layers of carbon sandwiched together with honeycomb Kevlar in between. The lever principle with these two layers, and the slight curve of the sides, makes these materials stronger yet, lending a 'non-stretching' effect. And making it one of the strongest materials in the world.

The wooden fronts and backs are made of four 70mm thick layers of solid wood and wood materials, sandwiched together with deadening glue. The lever principle applies here, too, making them exceptionally rigid.

The feet are of Marten's own production and design, made of high quality stainless steel. BDR pucks and cones, made of solid carbon fibre, dampen any resonance remarkably effectively.

The binding posts and terminals are 'WBT Next Gen' and are made of minimized metal, providing extremely good signal properties.

The internal wiring is the new Jorma Design Statement. These are custom-made with a specially designed steel shielding giving zero distortion between the cables. In total, we use 60 metres of this exceptional wiring.

The crossover is an entirely new approach. This technique, based on the joint venture with Accuton and their CELL technology, creates a sound which is 100% time and phase coherent.

This means that all the frequencies are rendered and outputted at the exact same moment. Very few loudspeakers are capable of this.

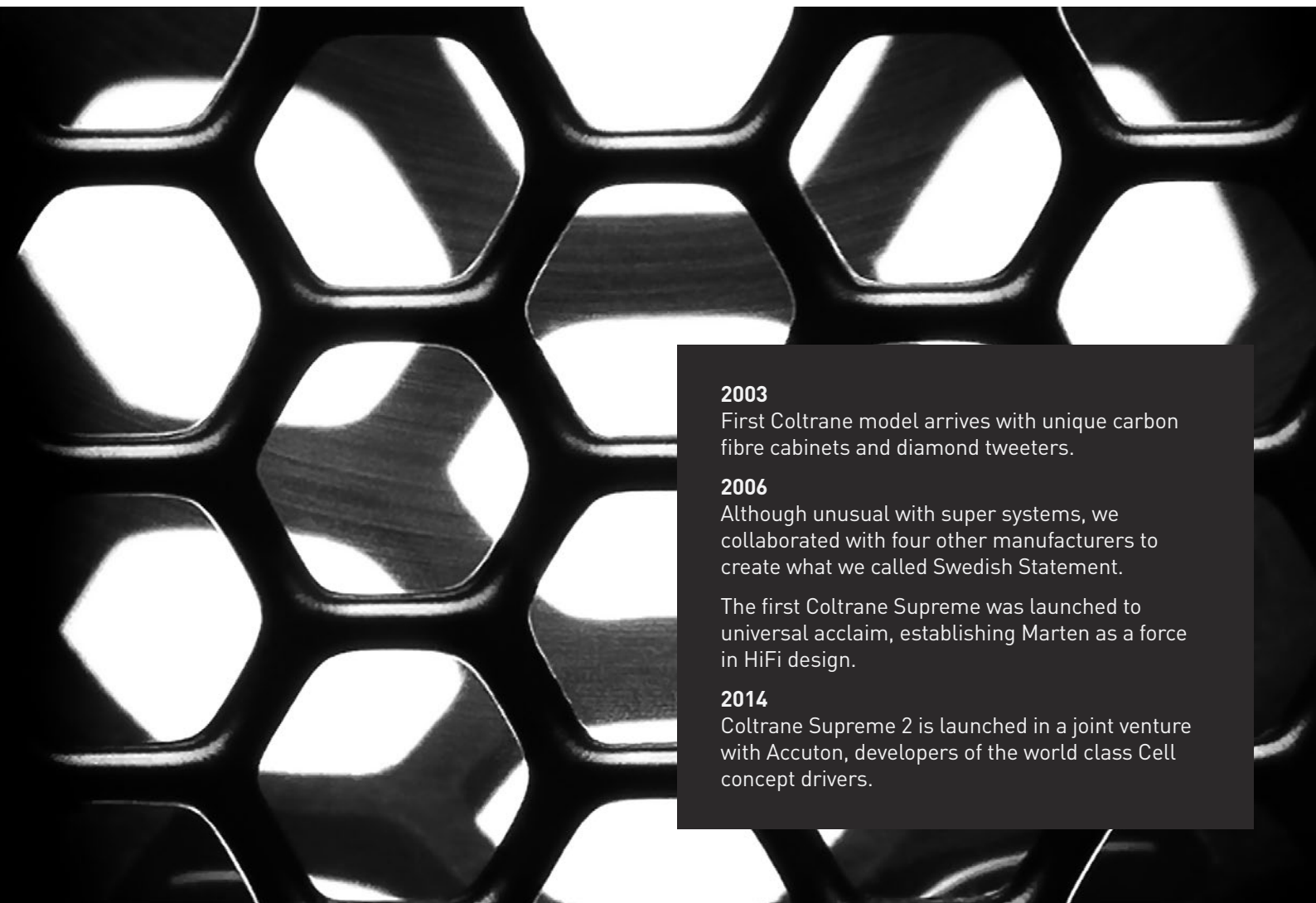

2003

First Coltrane model arrives with unique carbon fibre cabinets and diamond tweeters.

2006

Although unusual with super systems, we collaborated with four other manufacturers to create what we called Swedish Statement.

The first Coltrane Supreme was launched to universal acclaim, establishing Marten as a force in HiFi design.

2014

Coltrane Supreme 2 is launched in a joint venture with Accuton, developers of the world class Cell concept drivers.

COLTRANE SUPREME 2

The units all employ the newly developed Cell drivers.

Speaker (front):

- One 20mm diamond tweeter
- One 51mm lower treble diamond tweeter
- One 5" ceramic mid range unit
- One 8" aluminium laminated sandwich mid-bass driver
- Six 8" aluminium laminated sandwich bass drivers

Speaker (back):

- Six 11" sandwich passive radiators with the bass' lowest below 40Hz

CELL concept drivers

Our joint venture with Accuton represents a new milestone in hi-fi history. Accuton developed the unique CELL concept drivers used within the Coltrane Supreme 2. Tweeters, midrange and bass drivers have identical acoustic centres, delivering flawless phase and time coherency. The domes in the units are perfectly rigid, for impeccable signal settle and piston behaviour. And there is incredibly low distortion, in the magnitude of electronic devices, even at high levels.

- Steady decay of higher order harmonics
- High bandwidth



Technical specifications

Frequency range / 18-100000 Hz +-2dB

Power rating / 500 W

Sensitivity / 91 dB / 1 m / 2.83V

Impedance / 6 ohm (3.2 Ohm min)

Type / 5-way

Drive units / 6 x 11" passive sandwich, 7 x 8" alu sandwich, 1 x 5" ceramic, 1 x 2" diamond, 1 x 0.75" diamond

Crossover frequency / First order: 120, 450, 3500 & 8000 Hz

Terminals / WBT Nextgen bi-wiring

Internal wiring / Jorma Design Statement

Cabinet / 25mm:s carbon fibre laminate sides, 70mm solid laminated wood front, back, top and bottom

Stands / Polished stainless steel with Black Diamond Racing pucks and cones

Dimensions (WxHxD) / 54 x 200 x 59 (21.2 x 78.8 x 23.2")

Net weight / 230 Kg (507 lbs)

Finishes

All models have high-gloss carbon fibre cabinets with fronts available in:



Matt Oak



Matt Maple



Matt Cherry



Matt Walnut

Please note Colours may not be a true representation of actual finish.

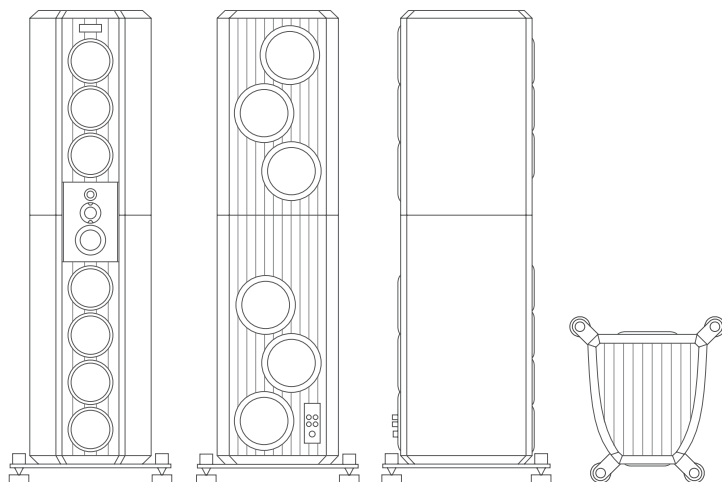

Marten
Chalmersgatan 24
SE-411 35 Gothenburg
Sweden

Tel: +46 31 20 72 00
Fax: +46 31 20 72 70
info@marten.se
www.marten.se

Made in Sweden